

OIL SKIMMER	
COMPANY NAME	WOOJIN INDUSTRY
TYPE	BEST OIL SKIMMER
MODEL	SDB300W * 500W * 3-ST
CAPACITY	1.5 ~ 300 L/H
POWER	220V 3P 60Hz / 120V
MOTOR	3-HP
www.skimmer.co.kr TEL: 031-366-3645 FAX: 031-225-9733	

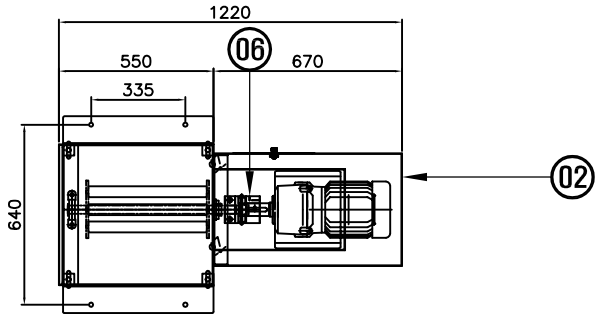

NO	DESCRIPTION	Q. TY	MATAL	SIZE	REMARK
01	BODY	1	STSS04	500*550*1330	
02	MOTOR COVER	1	STSS04	670*400*345	
03	DRIVE WHEEL SHAFT	1	STSS04	□30*594	
04	BEARING	1	STSS04	UP006	
05	BEARING	1	STSS04	MK006	
06	COUPLING	1	A/L	DJC95C RD-30*45	
07	MOTOR	1	CAST IRON	120:1	
08	DRIVE WHEEL	1	STSS04	□205*436L	
09	TAIL WHEEL	1	STSS04	□205*436L	
10	TAIL WHEEL SHAFT	1	STSS04	□30*490	
11	BELT	1	NITRILE	400*4200L*5.5T	
12	SCRAPER	2	STSS04	467*100*18	
13	SCRAPER BODY	1	STSS04	625*320*225	
14	WHEEL SUPPORT	1	STSS04	472*300*80	
15	EYEBOLT	4	STSS04	M16	
16	DOOR	1	STSS04	290*170*1.5T	
17	NAME PLATE	1	STSS04	300*200	
18	DRAIN VALVE	1	STSS04	40A	
19	CHAIN	1	STSS04	50*24	
20	OVERFLOW	1	STSS04	40A	
21	CHAIN SUPPORT	1	STSS04	285*100*□50	
22	DOOR LOCK	1	CHROME	S1-51	
23	OIL OUT LINE	1	STSS04	40A	

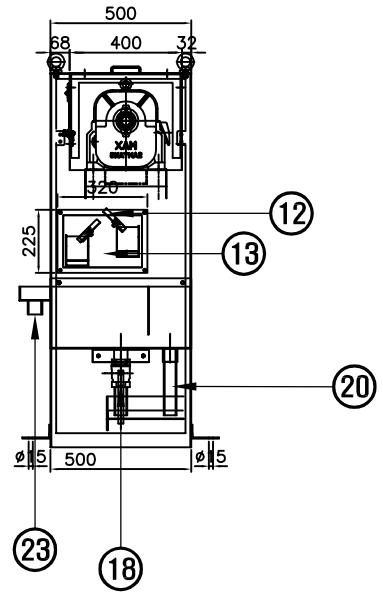
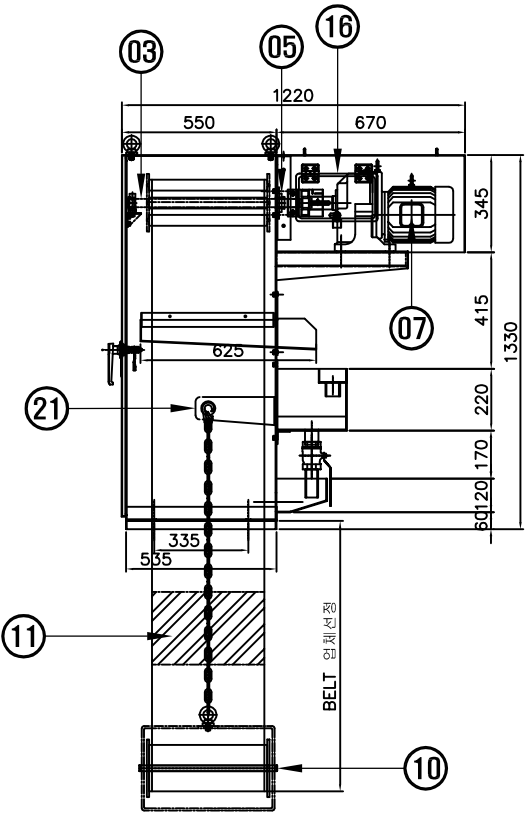
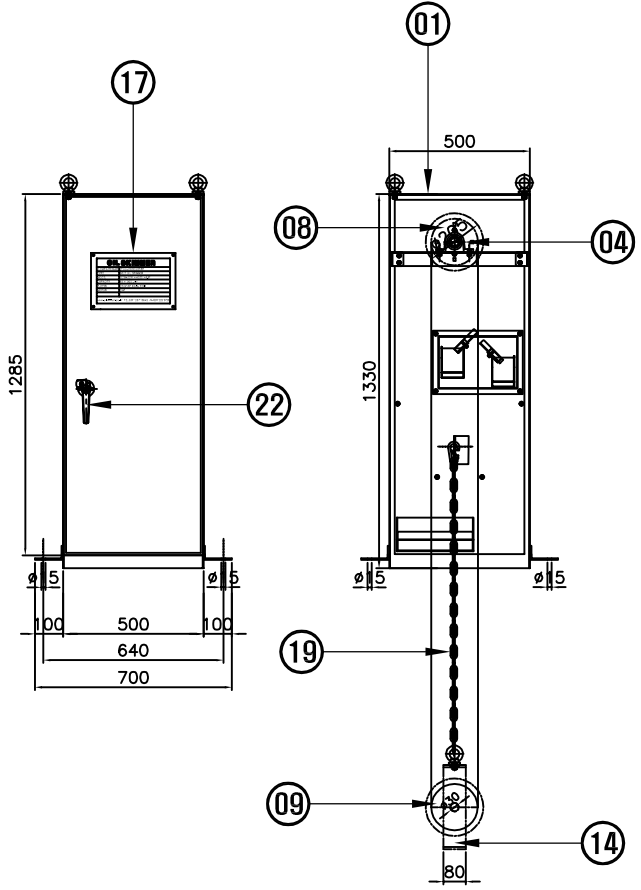

REV		DATE	DESCRIPTION	THIS DRAWING CONTAINS PROPRIETARY AND CONFIDENTIAL INFORMATION OF PKG AND SHOULD BE MAINTAINED IN STRICT CONFIDENCE. DO NOT COPY OR TRANSFER TO ANY PARTY.			BY	DATE	 www.skimmer.co.kr TEL : 031-366-4262 FAX : 031-366-4263 경기도 화성시 향남읍 한두골길 82	SCALE	TITLE	CUSTOMER	PROJECT NO.
DWG				S.J.W							오일스키머 SDB300-500W(SUS304제작)		
CHK'D													
APP'R'D													

A3(420x297)